

DSCP81



Configurable Voltage/Current Input Signal Conditioners, DIN Mount

Description

Each isolated DSCP81 signal conditioner is designed for measuring voltages up to $\pm 1000\text{VDC}$ and currents up to $\pm 100\text{mA}$. The input type, measurement range, and other features are software configurable. A PC with RS-232C serial port, the DSCX-787 and DSCX-587 interface cables, and the DSCX-557 configuration software are required to program the DSCP81.

The DSCP81 can interface to either a current or voltage input and provide a current or voltage output (Figure 1). The input filter characteristics, input and output ranges, input signal linearization, signal inversion, and optional alarm relay output are all software configurable by the user. The input signal may be linearized using up to 50 points of interpolation. Optionally, the user may specify all configurable parameters.

Two models are available offering wide-range power supply connection: 24 to 60VDC/AC, and 85 to 230VDC/AC. The DSCX-557 configuration software allows query, print-out and saving of configuration settings, display of input measurement value, and display of interpolation table points.

Features

- Interfaces to Voltages up to $\pm 1000\text{VDC}$ and Currents up to $\pm 100\text{mA}$
- Software Configurable Input Type and Range
- Software Configurable Filter
- 3700Vrms Transformer Isolation
- Supply Voltage of 24 to 60VDC/AC or 85 to 230VDC/AC
- Alarm Relay Output
- Mounts on Standard DIN Rail
- -25C to $+55\text{C}$ Operating Temperature
- CE Compliant

⚠ There is impending danger of high voltage on any DSCP81 connections from high input voltage or high power supply voltage.

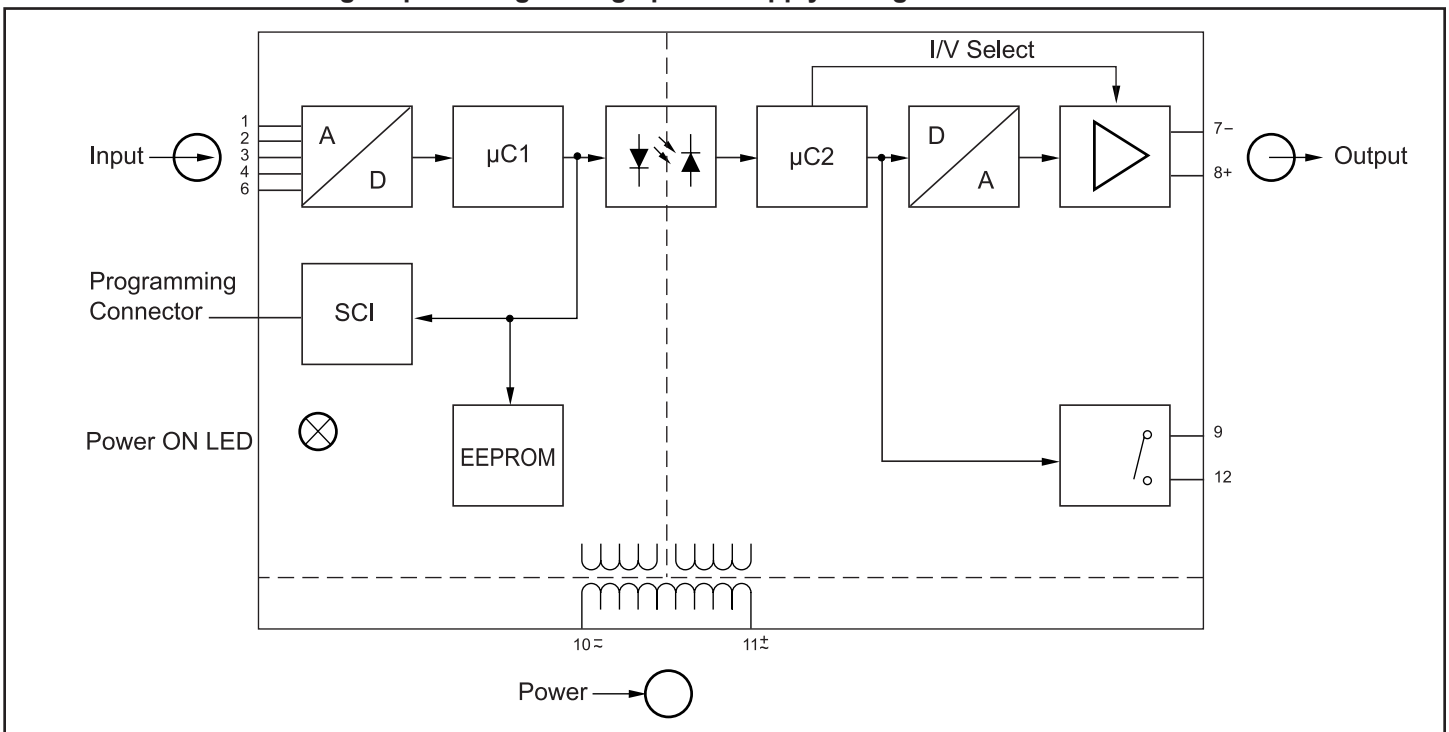

Figure 1: DSCP81 Block Diagram

Specifications Typical* at T_A = +25°C and 24VDC or 230VAC ±10% supply voltage

Module	DSCP81
Input Range, Voltage Input Resistance	-1000VDC to +1000VDC max, Configurable 1MΩ (V _{IN} ≤ ±1.7V), 540kΩ (V _{IN} > ±1.7V to ≤ ±100V), 5.5MΩ (V _{IN} > ±100V to ±1000V)
Input Range, Current Input Resistance	-100mA to +100mA max, Configurable 1kΩ (I _{IN} = -1.5mA to +1.5mA), 15.4Ω (I _{IN} = -100mA to +100mA)
Output Range, Voltage V Limit Under Overload Short Circuit Current External Resistance	-10V to +10V max, Configurable Approx. ±11V ≤60mA R _{ext} min (kΩ) ≥ V _{ov} /10mA Note: V _{ov} = Output Voltage End Value
Output Range, Current Output Load Voltage Current Limit Under Overload Open-Circuit Voltage External Resistance	-20mA to +20mA max, Configurable 12V Approx. ±22mA <16V R _{ext} max (kΩ) = 12V/I _{ov} Note: I _{ov} = Output Current End Value
Output Ripple (Voltage or Current)	<0.5% p-p
CMV, Input to Output & Relay	3700Vrms, 1 min.
CMV, Power Supply to Input & Output	3700Vrms, 1 min.
CMV, Power Supply to Relay	2300Vrms, 1 min.
CMV, Output to Relay	2300Vrms, 1 min.
Mains Ripple Suppression Input Filter	Configurable to 50 or 60Hz Configurable, see Table 1
Accuracy ⁽¹⁾ Output Stability	±0.1% Span Typ., ±0.2% Span max. 100ppm/°C
Linearization	Configurable; Linear, Custom, x ^{1/2} , x ^{3/2} , x ^{5/2}
Alarm Relay Material Contact Rating	SPST Isolated Contact Gold Flashed Silver Alloy AC: ≤2A at 250V (500VA), DC: ≤2A at 125V (60W)
Mode of Action	Configurable; Alarm and Power Loss (see Table 2 Feature 6)
Trip Point Type	Configurable; Inactive, Low, High (see Table 2 Feature 7)
Trip Point Setting	Configurable, -10 to 110% Input Span (see Table 2 Feature 7)
Trip Point Hysteresis	Configurable, 0 to 100% Input Span (see Table 2 Feature 7)
Energize/De-energize Delay	Configurable, 0.01 to 1000s (see Table 2 Feature 8)
Visible Alarm	Front Panel Green LED flashes "ON"
Power Supply Voltage	24 to 60VDC/AC, or 85 to 230VDC/AC; 45 to 400Hz AC
Tolerance Power Consumption	DC -15% to +33%, AC ±15% DC ≤1.2W, AC ≤2.5VA
Mechanical Dimensions (h)(w)(d)	2.72" x 0.69" x 4.49" (69.2mm x 17.5mm x 114mm)
Housing Material	Lexan 940, Flammability Class V-0 According to UL 94
Mounting	DIN EN 50022 -35x7.5 or -35x15
Environmental Operating Temperature Range Storage Temperature Range Relative Humidity	-25°C to +55°C -40°C to +70°C 0 to 75% Noncondensing
Emissions Immunity	EN50081-2 (Radiated, Conducted) EN50082-2 (ESD, RF, EFT)

Ordering Information

Model	Input Range/Description	Output Range
DSCP81-01 (Standard Configuration ⁽²⁾)	User Configurable V or I Input, 24 to 60VDC/AC Power	User Configurable V or I Output
DSCP81-02 (Standard Configuration ⁽²⁾)	User Configurable V or I Input, 85 to 230VDC/AC Power	User Configurable V or I Output

Accessories

Model	Description
DSCX-787	PC Interface Cable
DSCX-587	Module Interface Cable
DSCX-557 ⁽³⁾	Configuration Software

Table 1: Configurable Input Filter Settings

Response Time (63%) [s]		Response Time ⁽⁴⁾ (99%) [s]	
50Hz	60Hz	50Hz	60Hz
0.04	0.03	0.08	0.07
0.06	0.05	0.17	0.14
0.10	0.08	0.36	0.30
0.18	0.15	0.72	0.60
0.34	0.28	1.5	1.2
0.66	0.55	3.0	2.5
1.3	1.1	6.0	5.0
2.6	2.2	12	10
5.1	4.3	24	20
10.3	8.6	48	40
20.5	17	94	80
41	34	190	160
82	68	380	315
160	140	750	630
330	270	1500	1260

NOTES:

*Contact factory or your local Dataforth sales office for maximum values.

(1) Includes linearity and repeatability errors at reference conditions.

(2) Shipped as 4 to 20mA input, 4 to 20mA output, linearization = linear, input filter = 80ms, ripple suppression = 60Hz, alarm function = inactive.

(3) Downloadable from website.

(4) Configuration software allows selection of the (99%) values.

Figure 2: Switching Function by Trip Point Type

Alarm Relay Features ⁽¹⁾	
Trip point type:	Configurable as low or high or inactive
Trip point adjustment:	Configurable between -10 and 110% ⁽²⁾
Hysteresis:	Configurable between >0 and 100% ⁽²⁾
Energize/De-energize delays:	Configurable between 0 and 1000s
Relay contact position:	Configurable
Front panel display:	Green LED "ON" flashes when the limit value is exceeded.

NOTES:
 (1) Refer to Table 2 for connections
 (2) In relation to the analog input span

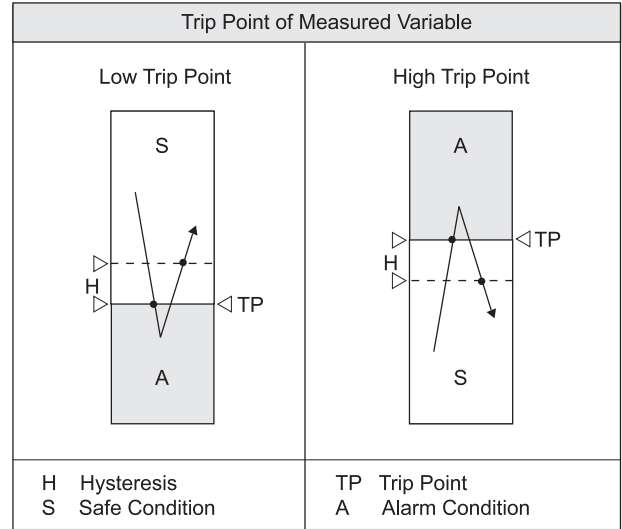
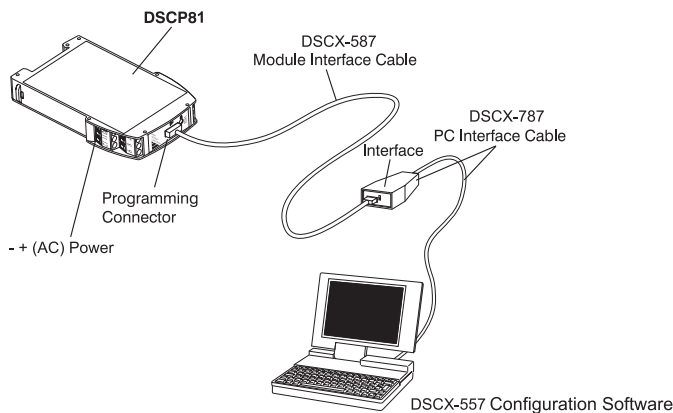

Table 2: Input Range and Associated Connection Diagram

Measuring Mode/Application	DC Voltage			DC Current
	≤ ± 1.7V	> ± 1.7 to ≤ ± 100V	> ± 100 to ± 1000V	≤ ± 100 mA
<p>⊖ ⊕ = Input Signal</p>				
<p>⊕ ⊖ = Output Signal</p> <p>⊕ ⊖ K = Output Contact</p> <p>⊖ ⊕ = Power Supply</p>				

Figure 3: Configuring the DSCP81



A PC, DSCX-787 PC interface cable, DSCX-587 module interface cable, and DSCX-557 configuration software are required to program the DSCP81. Power must be connected to the DSCP81 for configuration. The DSCX-557 configuration software is downloadable from the website.

IMPORTANT!

- 1. DO NOT** connect the DSCX-587 module interface cable to the DSCP81 programming connector when >253V is applied to the DSCP81 input.
- The DSCX-587 module interface cable must first be connected to the DSCX-787 cable before it is connected to the DSCP81.
- The programming connector on the DSCP81 is DC connected to the DSCP81 input circuit. **DO NOT** touch any metal parts of the plug or socket if an input voltage >24V is connected to the DSCP81.

Figure 4: Product Dimensions

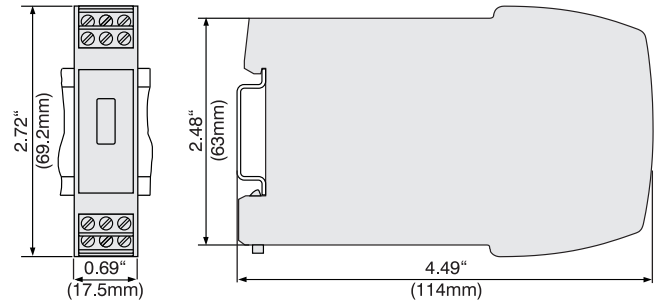
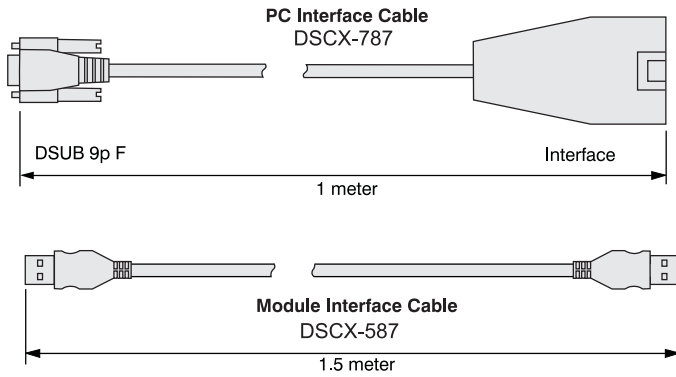

DSCP81 Clipped onto a Top-Hat Rail (35 x 15mm or 35 x 17mm, acc. to EN 50022).